

产品规格书

Product specification

产品名称/Product Name: 卷绕型超级电容器

规格型号/Part Number: NC12R73561S507SC(K)

签发日期/ Release Date: 2024年9月1日

Product specification	size
<u>2.7v 500F Snap-in</u>	35mm*65mm

目录 Contents

1. 适用范围 Scope of application.	1
2. 标准测试条件 Standard test conditions.	1
3. 标准产品外型尺寸 Standard product dimesion	1
4. 包装方式 Packing.	2
5. 产品性能特性 Product Performance Characteristics.	错误!未定义书签。
6. 超级电容器测试方法 Test methods of supercapacitors	4
7. 使用注意事项 Cautions for use.	6

1. 适用范围 Scope of application

本产品规格书描述了超级电容器 NC12R73561S507SC(K)的产品性能指标。

This product specification describes the performance indicators of super capacitor NC12R73561S507SC(K).

2. 标准测试条件 Standard test conditions

在标准大气压，温度 5~35℃，相对湿度小于 85 %条件下进行测试；本规格书标准测试条件为标准大气压，温度 25℃，相对湿度 25%~75%。

Products are tested under normal pressure, the temperature range is from 5-35°C and relative humidity is less than 85%RH. The standard test conditions in this product specification are as follows: under normal pressure; the temperature at 25°C and the relative humidity 25%~75%RH.

3. 标准产品外型尺寸 Standard product dimension

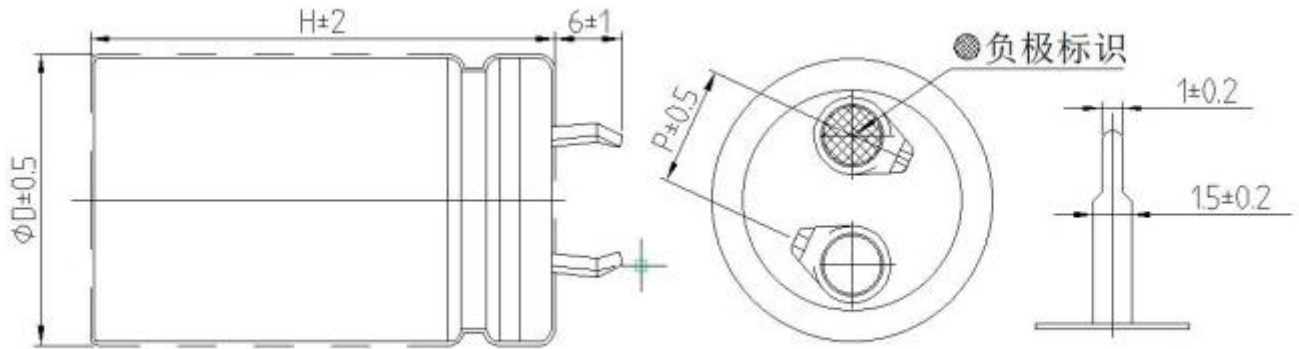

Items	Criteria	Items	Criteria
$D \pm 1$ (mm)	35	$H \pm 2$ (mm)	61

4. 包装方式 Packing

	Product model	Product size
NC12R73561S507SC(K)	2.7v 500F	35*60

5. 产品性能特性 LAproduct Performance Characteristics

项目名称	NC12R73561S507SC(K)	测试条件
工作温度范围 Operating temperature range	-40℃ ~+70℃	
额定工作电压 Rated working voltage	2.7V	
浪涌工作电压 Surge operating voltage	2.85V	
标称容量范围 Nominal capacity range Maximum continuous current $\Delta T=15^{\circ}\text{C}$	500F	25℃ $\Delta V=2.16-1.08$ I=75A
最大持续电流 ($\Delta T=25^{\circ}\text{C}$) Maximum continuous current $\Delta T=15^{\circ}\text{C}$	54A	
最大峰值电流 Maximum peak current	79A	测量温度 25℃
容量允许偏差 Allowable deviation of capacity	-0%~+20%	测量温度 25℃
最大内阻 (DC) Maximum internal resistance ESR (DC)	15m Ω	测量温度 25℃
72h 漏电流 (25℃) Leakage Current at 72h (25℃)	$\leq 1.5\text{mA}$	测量温度 25℃
质量 Weight	$\leq 69.5\text{g}$	
自放电特性 (电压保持特性) Self discharge characteristics (voltage holding characteristics)	正负极间电压大于等于 2.4V	充电过程: 常温, 无负载, 额定电压充电 24h 放置过程: , 温度小于等于 25℃, 相对湿度小于 60%RH, 开路放置 24H

项目名称		NC12R73561S507SC(K)	测试条件
温度特性 Temperature characteristic	容量 ΔC	步骤 1 满足初始规定值	步骤 1: $+25\pm 2^{\circ}\text{C}$ 步骤 2: $-40\pm 2^{\circ}\text{C}$ 步骤 3: $+70\pm 2^{\circ}\text{C}$
	ESR		
	容量 ΔC	步骤 2 小于等于 20%初始规定值	
	ESR		
	容量 ΔC	步骤 3 满足初始规定值 20%范围内	
	ESR		
耐久性 Endurance	容量 ΔC	满足初始规定值 20%范围内	施加电压: 2.7V 温度: $+70\pm 2^{\circ}\text{C}$ 时间: 1500h
	ESR	小于等于初始规定值 2 倍	
高低温循环特性 Temperature cycle	容量 C	满足初始规定值	温度循环: $-40\pm 2^{\circ}\text{C} \rightarrow$ 常温 $\rightarrow +70\pm 2^{\circ}\text{C} \rightarrow$ 常温 循环次数: 5 次
	ESR		
	外观	无机械损伤或漏液	
循环寿命 Cycle life	容量 ΔC	满足初始规定值 20%范围内	施加电压: 2.7V 温度: $+25\pm 2^{\circ}\text{C}$ 循环次数: 1000000 次
	ESR	小于等于初始规定值 2 倍	
存放寿命特性 Shelf life	容量 C	满足初始规定值 20%范围内	施加电压: 0V 温度: $\pm 2^{\circ}\text{C}$ 时间: 1000h
	ESR	小于等于初始规定值 1 倍	
	外观	无漏液或机械损伤	

6. 超级电容器测试方法 Test methods of super capacitors

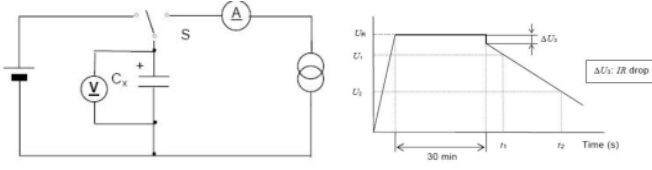
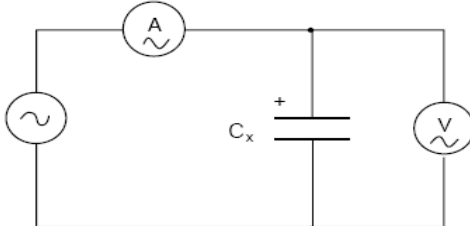
测试项目 Test project	测试方法 Test method
<p>1</p> <p>容量 capacity</p>	<p>恒流放电法测量:</p> <ol style="list-style-type: none"> 1、恒流/恒压源的直流电压设定为额定电压 (U_R)。 2、设定规定的恒电流放电装置的恒定电流值。 3、将开关 S 切换到直流电源, 在恒流/恒压源达到额定电压后恒压充电 30min。 4、在充电 30min 结束后, 将开关 S 变换到恒流放电装置, 以恒定电流进行放电。 5、测量电容器两端电压从 U_1 到 U_2 的时间 t_1 和 t_2, 如图所示, 根据下列等式计算电容量值: <p>Constant Current Discharge of Measure</p> <ol style="list-style-type: none"> 1、Set the DC voltage source to the rated voltage (U_R). 2、Sets constant current values of a specified constant current discharge device. 3、Switch the switch S to DC power supply , constant voltage charge for 30min after the voltage reaches to rated voltage. 4、After charging 30min , transform the switch S to constant current discharge devicethe to discharge at constant current. 5、 Measure the discharge time from U_1 to U_2 (t_1、 t_2), Calculate capacitance using the following formula:  $C = \frac{I \times (t_2 - t_1)}{U_1 - U_2}$
<p>2</p> <p>内阻 Resistance</p>	<p>交流阻抗方法测量</p> <p>采用如下图所示的电路进行测量:</p> <p>电容器的内阻 R_a 应通过下式计算: $R_a = \frac{U}{I}$</p> <p>R_a 交流内阻 (Ω); U 交流电压有效值 (V r. m. s);</p> <p>I 交流电流有效值 (V r. m. s)。</p> <p>Equivalent series resistance:</p> <p>ESR shall be measured from the circuit below:</p> <p>ESR R_a can be calculated from the formula: $R_a = \frac{U}{I}$</p> <p>Equivalent series resistance ($m\Omega / \Omega$);</p> <p>U Ac voltage valid values (V r. m. s);</p> <p>I Ac current valid values (V r.m.s)。</p> 

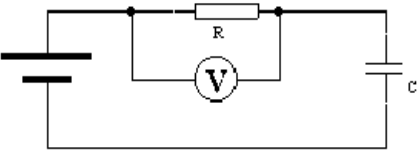
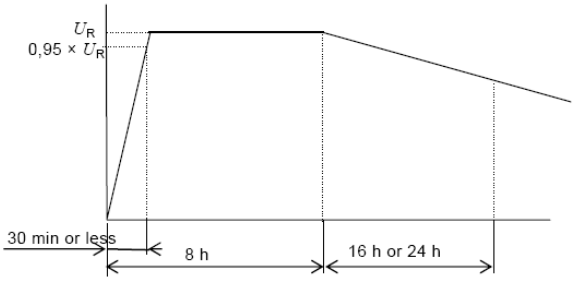
<p>3</p>	<p>漏电流 Leakage Current</p>	<p>直流漏电流的测量原理如下</p> <ol style="list-style-type: none"> 1、放电：该测量开始前，电容器应进行充分放电。放电过程持续1h到24h。 2、漏电流的测量应额定温度和额定电压 (U_R)。经过最大30min充电时间后达到95%充电电压，充电时间从30min ($\leq 1F$)，1h ($\geq 1F$)，2h ($\geq 10F$)，4h ($\geq 20F$)，72h ($\geq 120F$) 中选择。 3、应使用稳定的电源如直流稳压电源。 4、通过1000 Ω 以下的保护电阻给电容器施加电压。 <p>Leakage Current shall be measured from the circuit below:</p> <ol style="list-style-type: none"> 1、 Discharge: Before the start of the measurement, supercapacitor should be fully discharge, discharge process for 1 h to 24 h. 2、 Leakage current measurement shall be carried out under the rated temperature and voltage rating(U_R).The voltage of product reached 95% rated voltage after the biggest charging time for 30min, Charging time chooses from 30min($\leq 1F$), 1h($\geq 1F$), 2h($\geq 10F$), 4h($\geq 20F$), 72h($\geq 120F$). 3、 Should use a stable power supply, such as DC regulated power supply. 4、 Charge process should be through the protection under 1000 Ω resistance. 
<p>4</p>	<p>自放电 Self discharge</p>	<p>测量开始前，电容器应进行充分放电，放电过程持续 1h 到 24h，在电容器两端直接施加额定电压 U，不使用保护电阻，充电时间为 8h，包括电压达到施加电压 95%的最大 30min 充电时间，将电容器两端从电压源断开。电容器应置于标准常温常压条件下放置 24h。直流电压表的内阻应大于 1M Ω。</p> <p>Before the start of the measurement ,super capacitor should be fully discharge, discharge process for 1 h to 24 h.Charge the super capacitor to rated voltage without protection resistance,charging time for 8h(include the voltage of product reached 95% rated voltage after the biggest charging time for 30min).Disconnect the super capacitor from the power supply.Super capacitor should be placed in the standard atmospheric pressure conditions for 24 h. Dc voltmeter internal resistance should be greater than 1 m Ω .</p> 

7.使用注意事项 Cautions For Use

- (1) 超级电容器具有固定的极性；
- (2) 超级电容器应在标称电压下使用；
- (3) 超级电容器不可应用于高频率充放电的电路中；
- (4) 环境温度影响超级电容器的寿命；
- (5) 在放电的瞬间存在电压降 $\Delta V=IR$ ；
- (6) 不可存放于相对湿度大于 85%或含有有毒气体的场所；
- (7) 应储存在温度 $-30^{\circ}\text{C}\sim 50^{\circ}\text{C}$ 、相对湿度小于 60%的环境中；
- (8) 超级电容器用于双面电路板上时，要注意连接处不可经过电容器可触及的地方；
- (9) 安装后，不可强行扭动或倾斜电容器；
- (10) 在焊接过程中要避免使电容器过热（1.6mm 的印刷线路板，焊接时应为 260°C ，时间不超过 5s）
- (11) 焊接后，线路板和电容器要清洗于净；
- (12) 超级电容器串联使用时，存在单体间的电压均衡问题；
- (13) 其它使用上的问题，请向本公司咨询或参照超级电容器使用说明的相关技术资料执行。

- (1) Super capacitors have fixed polarity;
- (2) Super capacitors should be used under nominal voltage;
- (3) Super capacitors should not be used in high frequency charge-discharge circuits;
- (4) Ambient temperature affects the life of the super capacitor;
- (5) At the moment of discharge, there is a voltage drop $\Delta V= IR$;
- (6) Do not store in places with relative humidity greater than 85% or containing toxic gases;
- (7) It should be stored in an environment where the temperature is $-30^{\circ}\text{C}\sim 50^{\circ}\text{C}$ and the relative humidity is less than 60%;
- (8) when the super capacitor is used on the double-sided circuit board, it should be noted that the connection should not pass through the place that the capacitor can touch;
- (9) After installation, do not forcibly twist or tilt the capacitor;
- (10) Avoid overheating of the capacitor during welding (for a 1.6mm printed circuit board, the welding time shall be 260°C and the welding time shall not exceed 5S)
- (11) After welding, the circuit board and capacitor should be cleaned;
- (12) When super capacitors are used in series,it need balanced circuit of each cap;
- (13) For other problems in use, please consult our company or refer to the relevant technical materials in the instructions for the use of super capacitors.